



03.W3126 Random Headlight Flasher
with Extra Power Wire
INSTRUCTIONS

Attention Installers: This flasher must be installed by a qualified technician.

It is the final responsibility of the installer of headlight flashers to determine their compatibility with the vehicle make and model in which they will be installed. Incorrect wiring of headlight flashers could result in costly problems or even permanent damage to the vehicle's computer module.

NOTE: Do not install any **SHO-ME**® headlight flashers on 2000 model year or newer Dodge Durangos or Dodge Dakotas. Our flashers are **not** compatible with these vehicles and may lead to the failure of their computer systems.

CAUTION!

This flasher **MUST** be wired through a circuit controlled by the ignition switch
DO NOT wire directly to the battery.

This flasher is designed to flash high beam headlights on vehicles with negative ground headlight systems. This flasher produces multiple flash patterns using the vehicle's existing high beam headlights. When the flasher is in operation, one of six different flash patterns will be selected at random. This flash pattern will run for a short time, before the next pattern is selected at random. Provisions have been included in the flasher to prevent a particular pattern from being selected while that pattern is running. Therefore, the pattern is constantly changing, and will not repeat itself.

This flasher incorporates "Low Power Switching" for both the Control Switch input and the Override input. Therefore, the Positive 12V input must be connected to +12V at all times in order for the headlights to function normally. This feature also allows the flasher to be turned on by use of an existing switch, without overloading the switch.

Before installation of this flasher, check the existing wiring of the vehicle headlights. The ground wire of the headlights must be grounded at all times for this flasher to operate properly. Check **BOTH** headlights for ground while the vehicle is off, on, headlights on and off, and while daytime running lights are active (if applicable). If the ground wire for the headlights is not at ground potential at **all** times, find the reason and remedy **before** installation of the flasher. If there is a daytime running light module that is removing the ground from one or both lights, a relay may be installed to temporarily disable the running light module any time the flasher is to be operational (i.e. connect the relay to the same switch that turns on the flasher). (Vehicle manufacturers generally provide a way to disable the running lights via the power to the running light module, emergency brake light switch, etc.) Or if the circumstances of the installation permit, disable the running lights permanently.

In addition, ensure that the vehicle is not using "Ground Switching" or "Positive Ground" to control the headlights. Ground Switching means that the headlight "Common" wire is connected to +12V, and the headlight is activated when the dimmer switch (or relay) connects ground (0V) to the high OR low beam. If the vehicle has "Ground Switching" use model 03.W3031 instead.

As the flasher is being installed, ensure that the output of the flasher is the only wire going to the positive high beam wire on each side. The wires that originally went to the high beams, can generally be connected to the Override terminal of the flasher (rather than going all the way back to the actual dimmer switch). Use minimum of 16ga. wire for the headlights and Positive input of the flasher. The ground and control wires may be 18ga. wire minimum.

When selecting a location to mount the flasher, keep in mind that the life of any electronic device is directly dependent on the temperature in which it is operated - the cooler the unit, the longer the life.



PRODUCTS COMPANY 804 East Hwy 248 Cassville, MO 65625
U.S. and Canada Toll Free Numbers Phone: 800-641-4098 FAX: 800-526-1240
E-mail: sales@able2products.com WEB: www.able2products.com

Operation: When the flasher is installed properly in the vehicle, the headlights will flash any time +12V is applied to the Control Switch wire of the flasher. Anytime +12V is applied to the Override wire of the flasher, both headlights will come on steady. This function will "override" the flashing function of the flasher, allowing normal use of the high beam lights.

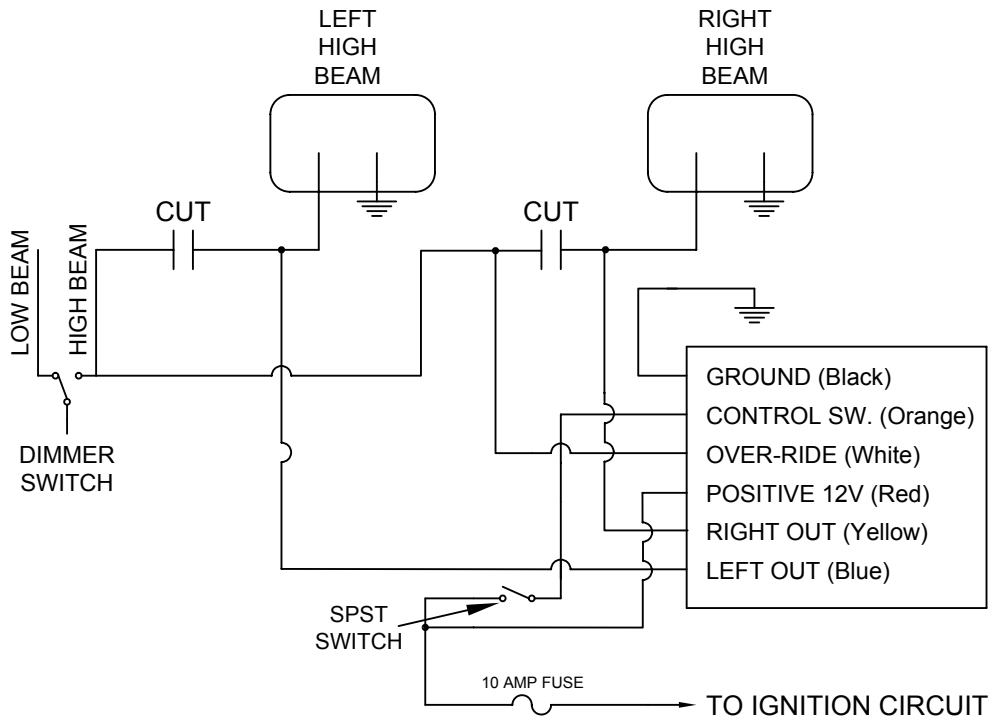

LIMITED WARRANTY

Able 2 Products Company warrants each new product (except bulbs, strobe tubes, strobe power supplies and LED Products) to be free from defects in material and workmanship for a period of two years from the date of purchase. During this warranty period, the obligation of Able 2 is limited to repairing or replacing, as Able 2 may elect, any part or parts, which after examination by Able 2 are determined to be defective, when they are delivered pre-paid. This limited warranty does not cover travel expense, the cost of specialized equipment for gaining access to the product, or labor charges for the removal and re-installation of the product.

Able 2 Products Company shall not be liable for incidental or consequential damages, including but not limited to: Loss of use of vehicle, Rental of substitute vehicle, Loss of time, Loss of work, Inconvenience, Transportation expenses, Telephone, Lodging, Loss of revenue, Loss of and /or damage to personal property for or arising out of breach of any express or implied warranty of its products.

Use of lamp or other electrical load of a wattage higher than installed or recommended by the factory, or use of inappropriate or inadequate wiring or circuit protection causes this limited warranty to become void. Able 2 Products Company will in no way be liable for any loss of profits or any indirect or consequential damages arising out of any such defect in material and workmanship whether loss is due to negligence or breach of warranty. This limited warranty does not apply to shipping damage, accident, alteration, tampering, misuse or abuse and unauthorized service.

This limited warranty is expressly in lieu of all other express or implied warranties, including the implied warranty of merchantability and the implied warranty of fitness for a particular purpose, and of all other obligations or liabilities on the part of Able 2 Products Company. There are no warranties, unless expressed in authorized Able 2 literature, which extend beyond the description of the face hereof. No dealer, distributor, employee, or representative of the company is authorized to change this warranty in any way or to grant any other warranty.

WARRANTIES:	All LED Products	5 Years
	T Model & Potted Strobe Power Supplies	2 Years
	All Other Strobe Power Supplies	5 Years
	All Other Products EXCEPT Bulbs	2 Years (under normal use)
	Strobe Tubes	1 Year (under normal use)
	NOTE: Halogen and Incandescent Bulbs are not covered by warranty.	

PRODUCT RETURNS

If a product must be returned, contact our factory by calling 1-800-641-4098 to obtain a Return Authorization Number (RA) before you ship the product. Write the RA Number clearly on the package and return it to Able 2 Products Company, P.O. Box 543, 804 E. Hwy. 248, Cassville, MO 65625-0543. A packing slip should be included with all shipments listing the sender's name, address, daytime phone number and description of defect. Your product will be put in first-class operating condition or replaced with a new part, and returned pre-paid.