

SHO-ME®

Instructions

05.4040 / 05.4044 Four- Position Switch Box with 40 amp Relay and Breaker

GENERAL INSTRUCTIONS:

The 05.4040/4044 switch box contains a 40 amp relay and breaker which are controlled by the #1 switch. When the #1 switch is turned on, it will activate the **internally mounted 40 amp relay**, and be protected by the **internally mounted 40 amp breaker**. All other switches are 20 amp switches protected by a 20 amp fuse located on the back of the switch box .

INSTALLATION INSTRUCTIONS:

Determine mounting location. Keep in mind air bag deployment zones and any other obstructions. Mount where desired using bail mount and hardware supplied.

Connect "BLACK" 18 GA Ground wire to chassis ground.

Connect 10 GA "GREEN" wire to load to be operated by the #1 switch.

Connect all 16 GA switch wires as desired.

Connect both 10 GA "RED" wires to power source.

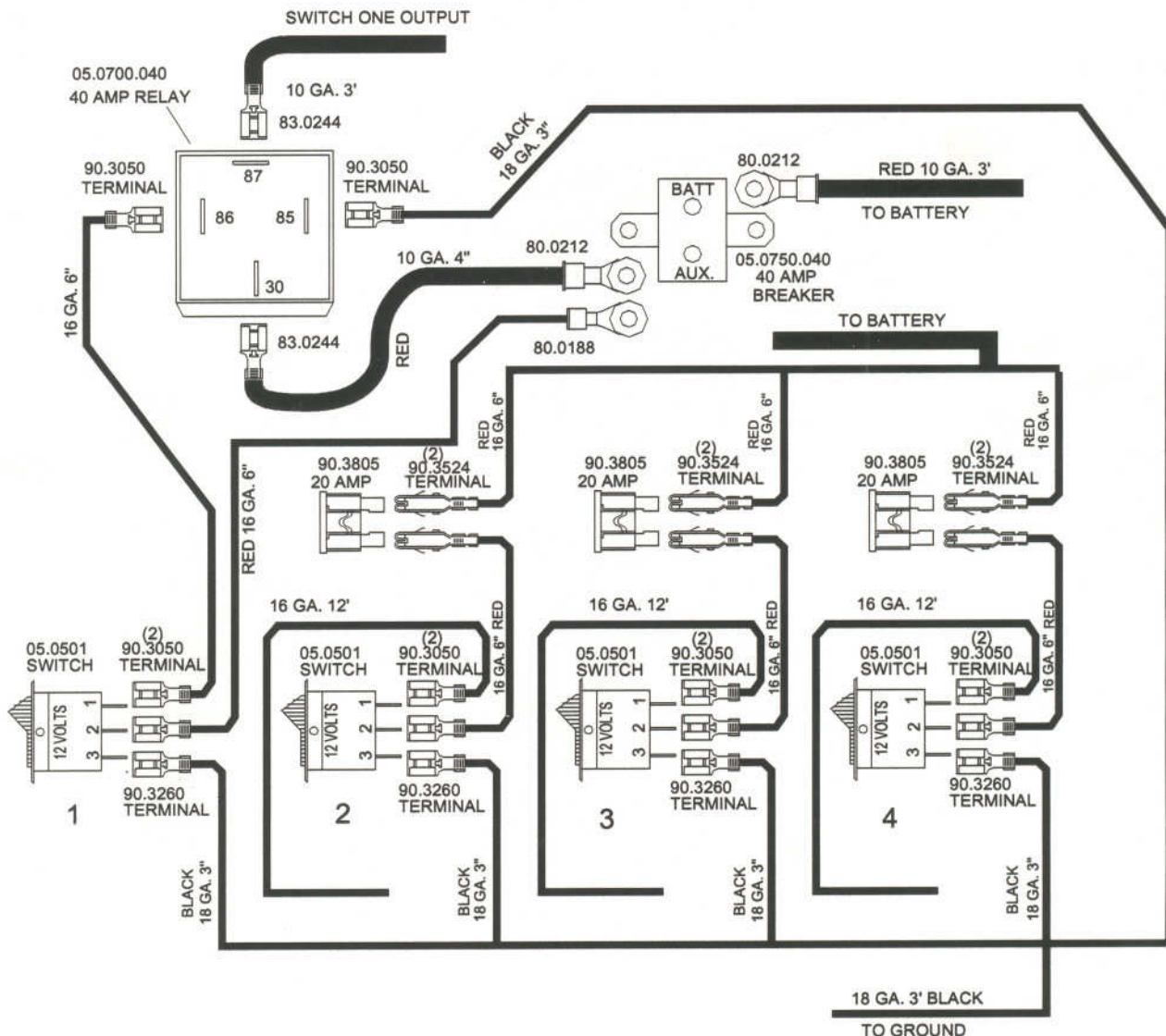

LIMITED WARRANTY

Able 2 Products Company warrants each new product (except bulbs, strobe power supplies and strobe tubes) to be free from defects in material and workmanship for a period of two years from the date of purchase. During this warranty period, the obligation of Able 2 is limited to repairing or replacing, as Able 2 may elect, any part or parts, which after examination by Able 2 are determined to be defective, when they are delivered pre-paid. This limited warranty does not cover travel expense, the cost of specialized equipment for gaining access to the product, or labor charges for the removal and re-installation of the product.

Able 2 Products Company shall not be liable for incidental or consequential damages, including but not limited to: Loss of use of vehicle, Rental of substitute vehicle, Loss of time, Loss of work, Inconvenience, Transportation expenses, Telephone, Lodging, Loss of revenue, Loss of and/or damage to personal property for or arising out of breach of any express or implied warranty of its products.

Use of lamp or other electrical load of a wattage higher than installed or recommended by the factory, or use of inappropriate or inadequate wiring or circuit protection causes this limited warranty to become void. Able 2 Products Company will in no way be liable for any loss of profits or any indirect or consequential damages arising out of any such defect in material and workmanship whether loss is due to negligence or breach of warranty. This limited warranty does not apply to shipping damage, accident, alteration, tampering, misuse or abuse and unauthorized service.

This limited warranty is expressly in lieu of all other express or implied warranties, including the implied warranty of merchantability and the implied warranty of fitness for a particular purpose, and of all other obligations or liabilities on the part of Able 2 Products Company. There are no warranties, unless expressed in authorized Able 2 literature, which extend beyond the description of the face hereof. No dealer, distributor, employee, or representative of the company is authorized to change this warranty in any way or to grant any other warranty.

PRODUCT RETURNS

If a product must be returned, contact our factory by calling 1-800-641-4098 to obtain a Return Authorization Number (RA) before you ship the product. Write the RA Number clearly on the package and return it to Able 2 Products Company, P.O. Box 543, 804 E. Hwy. 248, Cassville, MO 65625-0543. A packing slip should be included with all shipments listing the sender's name, address, daytime phone number and description of defect. Your product will be put in first-class operating condition or replaced with a new part, and returned pre-paid.

WARRANTIES: Strobe Power Supplies ----- 5 years
All other products (EXCEPT Bulbs) ---- 2 years (Under normal use)
Note: Strobe Tubes - 1 Year Warranty (Under normal use)
Halogen and Incandescent bulbs are not covered by warranty.



PRODUCTS COMPANY • 804 East Hwy. 248 • Cassville, MO 65625
U.S. and Canada Toll Free Numbers • Phone: 800-641-4098 FAX: 800-526-1240
E-mail: sales@able2products.com WEB: www.able2products.com